

moduł; module m	#1	#1.5	#2	#2.5	#3	#3.5	#4	#4.5	#5	#5.5	#6	#6.5	#7	#7.5	#8	kpl.; set
8	○	○	○	○	○	○	○	○	○	○	○	○	○	○	○	○

Nr freza w kpl. / Liczba zębów koła obrabianego;
Number of cutter in set / Range of teeth cut

Przykład zamówienia; Example of order: Frez; Involute gear cutter NFMb m=8#1



Na specjalne zamówienie wykonujemy narzędzia o wymiarach innych niż zawarte w tabeli;
For the special order we make tools of other dimensions than contained in table.

Frezy modułowe krążkowe do kół zębatych o zarysie ewolwentowym (m = 8); Involute gear cutters (m = 8 pcs)



Numer freza; Number of milling cutter	Liczba zębów koła obrabianego; Range of teeth cut
#1	9 ÷ 13
#2	14 ÷ 22
#3	23 ÷ 150

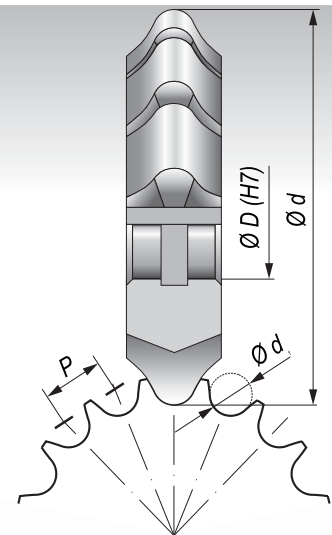

Podziałka P; Pitch P	Rolka d _r ; Roller d _r	d	D (H7)	Nr freza w kpl.; Number of cutter in set			
cale, inch	mm	mm	mm	#1	#2	#3	kpl.; set
5/16	7.94	4.76	63	22	○	○	○
3/8	9.525	6.35	70	27	●	●	●
1/2	12.7	8.51	75	27	●	●	●
5/8	15.875	10.16	85	32	●	●	●
3/4*	19.05	12.07	90	32	●	●	●
1"	25.4	15.88	100	32	●	●	●

Przykład zamówienia; Example of order: Frez; Milling cutter NFMt P=3/8#1



* - może służyć do nacinania uzębienia dla P=3/4", d₁=11.91 mm, jak również dla P=20 mm i d₁=12 mm;
can be used for cutting of teeth for P=3/4", d₁=11.91 mm, as well as P=20 mm and d₁=12 mm

Na specjalne zamówienie wykonujemy narzędzia o wymiarach innych niż zawarte w tabeli;
For the special order we make tools of other dimensions than contained in table.

DIN 844-(A, B) K-NR

www.fenes.com.pl

FREZY; END MILLS

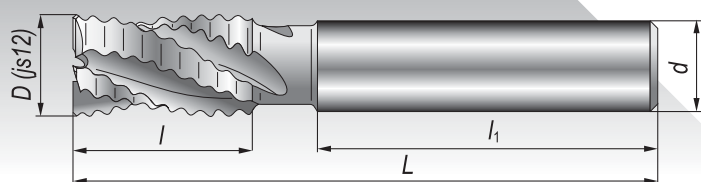

DIN 844-A K-M, A K



DIN 844-B K-M, B K



D _[js12]	d _[h8]	l	l ₁	L	Z	DIN 844-A K-M-NR		DIN 844-A K-NR	
						HSS-E	HSS-E Golden	HSS-E	HSS-E Golden
10	10	22	40	72	4	○	○	●	○
11	12	22	45	79	4	○	○	●	○
12	12	26	45	83	4	○	○	●	○
13	12	26	45	83	4	○	○	○	○
14	12	26	45	83	4	○	○	●	○
15	12	26	45	83	4	○	○	●	○
16	16	32	48	92	4	○	○	●	○
18	16	32	48	92	4	○	○	●	○
20	20	38	50	104	4	○	○	●	○
22	20	38	50	104	6	○	○	●	○
24	25	45	56	121	6	○	○	○	○
25	25	45	56	121	6	○	○	●	○
26	25	45	56	121	6	○	○	○	○
28	25	45	56	121	6	○	○	○	○
30	25	45	56	121	6	○	○	○	○
32	32	53	60	133	6	○	○	○	○

Przykład zamówienia; Example of order: Frez; End mill DIN 844-A 10 K-M-NR HSS-E

- Frezy; End mills DIN 844-B K-NR, B K-M-NR
- Frezy; End mills DIN 844-B K-NR, B K-M-NR Golden

Na specjalne zamówienie wykonujemy narzędzia o wymiarach innych niż zawarte w tabeli;
For the special order we make tools of other dimensions than contained in table.

DIN 844-(A, B) L-NR

FREZY; END MILLS

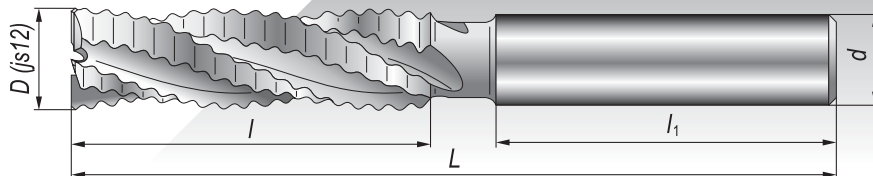

DIN 844-A L-M, A L



DIN 844-B L-M, B L

DIN 844-A L-M-NR

DIN 844-A L-NR



D _(js12)	d _(h8)	l	l ₁	L	Z	DIN 844-A L-M-NR		DIN 844-A L-NR	
						HSS-E	HSS-E Golden	HSS-E	HSS-E Golden
10	10	45	40	95	4	○	○	●	○
11	12	45	45	102	4	○	○	○	○
12	12	53	45	110	4	○	○	●	○
13	12	53	45	110	4	○	○	○	○
14	12	53	45	110	4	○	○	○	○
15	12	53	45	110	4	○	○	○	○
16	16	63	48	123	4	○	○	●	○
18	16	63	48	123	4	○	○	○	○
20	20	75	50	141	4	○	○	●	○
22	20	75	50	141	6	○	○	○	○
24	25	90	56	166	6	○	○	○	○
25	25	90	56	166	6	○	○	●	○
26	25	90	56	166	6	○	○	○	○
28	25	90	56	166	6	○	○	○	○
30	25	90	56	166	6	○	○	○	○
32	32	106	60	186	6	○	○	○	○

Przykład zamówienia; Example of order: Frez; End mill DIN 844-A 16 L-M-NR HSS-E

- Frezy; End mills DIN 844-B L-NR i B L-M-NR
- Frezy; End mills DIN 844-B L-NR i B L-M-NR Golden

Na specjalne zamówienie wykonujemy narzędzia o wymiarach innych niż zawarte w tabeli;
For the special order we make tools of other dimensions than contained in table.



DIN 845-B K-NR

www.fenes.com.pl

FREZY; END MILLS

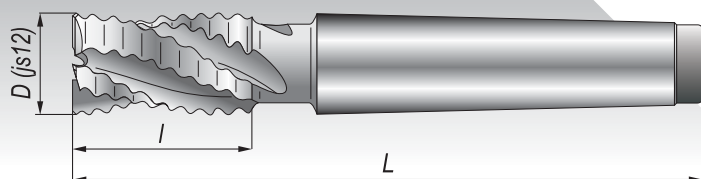

D _[js12]	I	L	Nr stoż.; MT	Z	DIN 845-B K-M-NR		DIN 845-B K-NR	
					HSS-E	HSS-E Golden	HSS-E	HSS-E Golden
10	22	92	1	4	○	○	○	○
11	22	92	1	4	○	○	○	○
12	26	96	1	4	○	○	○	○
13	26	96	1	4	○	○	○	○
14	26	111	2	4	○	○	●	○
15	26	111	2	4	○	○	○	○
16	32	117	2	4	○	○	●	○
18	32	117	2	4	○	○	●	○
20	38	123	2	4	○	○	●	○
22	38	123	2	6	○	○	●	○
24	45	147	3	6	○	○	○	○
25	45	147	3	6	○	○	●	○
26	45	147	3	6	○	○	○	○
28	45	147	3	6	○	○	○	○
30	45	147	3	6	○	○	●	○

Przykład zamówienia; Example of order: Frez; End mill DIN 845-B 10 K-M-NR HSS-E

Na specjalne zamówienie wykonujemy narzędzia o wymiarach innych niż zawarte w tabeli;
For the special order we make tools of other dimensions than contained in table.

DIN 845-B L-NR

FREZY; END MILLS

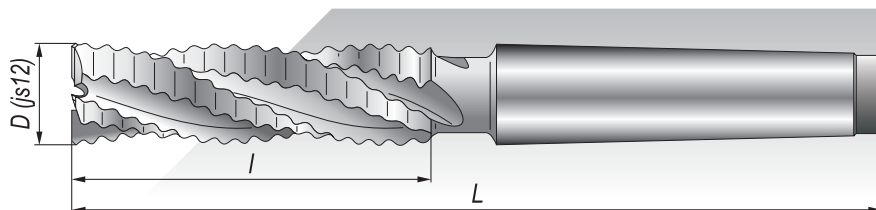

DIN 845-B L-M-NR

DIN 845-B L-NR



D _[js12]	l	L	Z	Nr stoż.; MT	DIN 845-B L-M-NR		DIN 845-B L-NR	
					HSS-E	HSS-E Golden	HSS-E	HSS-E Golden
10	45	115	4	1	○	○	○	○
11	45	115	4	1	○	○	○	○
12	53	123	4	1	○	○	○	○
13	53	123	4	1	○	○	○	○
14	53	138	4	2	○	○	○	○
15	53	138	4	2	○	○	○	○
16	63	148	4	2	○	○	●	○
18	63	148	4	2	○	○	○	○
20	75	160	4	2	○	○	●	○
22	75	160	6	2	○	○	○	○
24	90	192	6	3	○	○	●	○
25	90	192	6	3	○	○	●	○
26	90	192	6	3	○	○	○	○
28	90	192	6	3	○	○	○	○
30	90	192	6	3	○	○	○	○

Przykład zamówienia; Example of order: Frez; End mill DIN 845-B 10 L-M-NR HSS-E

Na specjalne zamówienie wykonujemy narzędzia o wymiarach innych niż zawarte w tabeli;
For the special order we make tools of other dimensions than contained in table.

DIN 844-(A, B) K / L-M-WR

www.fenes.com.pl

FREZY; END MILLS

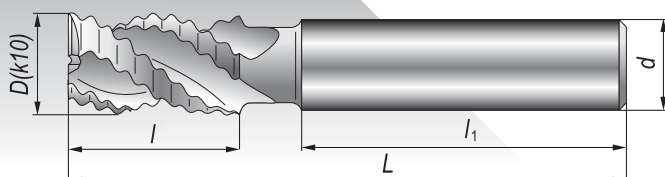

D _(k10)	d _(h8)	l	l ₁	L	Z	DIN 844-A K-M-WR		DIN 844-B K-M-WR	
						HSS-E	HSS-E Golden	HSS-E	HSS-E Golden
10	10	22	40	72	3	○	○	○	○
11	12	22	45	79	3	○	○	○	○
12	12	26	45	83	3	○	○	○	○
13	12	26	45	83	3	○	○	○	○
14	12	26	45	83	3	○	○	○	○
15	12	26	45	83	3	○	○	○	○
16	16	32	48	92	3	○	○	○	○
18	16	32	48	92	3	○	○	○	○
20	20	38	50	104	4	○	○	○	○
22	20	38	50	104	4	○	○	○	○
24	25	45	56	121	4	○	○	○	○
25	25	45	56	121	4	○	○	○	○
26	25	45	56	121	4	○	○	○	○
28	25	45	56	121	4	○	○	○	○
30	25	45	56	121	4	○	○	○	○
32	32	53	60	133	4	○	○	○	○

Przykład zamówienia; Example of order: Frez; End mill DIN 844-A 10 K-M-WR HSS-E

Frezy trzpieniowe walcowo-czołowe, krótkie do obróbki zgrubnej metali lekkich z chwytem walcowym;
Roughing end mills for light metals, short with straight shank

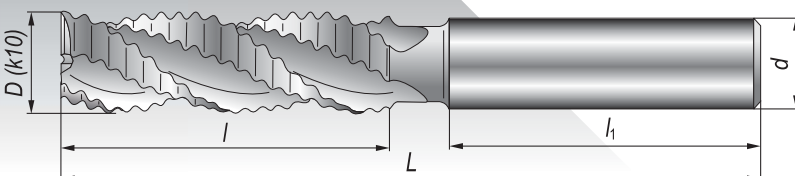

D _(k10)	d _(h8)	l	l ₁	L	Z	DIN 844-A L-M-WR		DIN 844-B L-M-WR	
						HSS-E	HSS-E Golden	HSS-E	HSS-E Golden
10	10	45	40	95	3	○	○	○	○
11	12	45	45	102	3	○	○	○	○
12	12	53	45	110	3	○	○	○	○
13	12	53	45	110	3	○	○	○	○
14	12	53	45	110	3	○	○	○	○
15	12	53	45	110	3	○	○	○	○
16	16	63	48	123	3	○	○	○	○
18	16	63	48	123	3	○	○	○	○
20	20	75	50	141	4	○	○	○	○
22	20	75	50	141	4	○	○	○	○
24	25	90	56	166	4	○	○	○	○
25	25	90	56	166	4	○	○	○	○
26	25	90	56	166	4	○	○	○	○
28	25	90	56	166	4	○	○	○	○
30	25	90	56	166	4	○	○	○	○
32	32	106	60	186	4	○	○	○	○

Przykład zamówienia; Example of order: Frez; End mill DIN 844-A 10 L-M-WR HSS-E

Na specjalne zamówienie wykonujemy narzędzia o wymiarach innych niż zawarte w tabeli;
For the special order we make tools of other dimensions than contained in table.

DIN 844-(A, B) K / L-M-W

FREZY; END MILLS

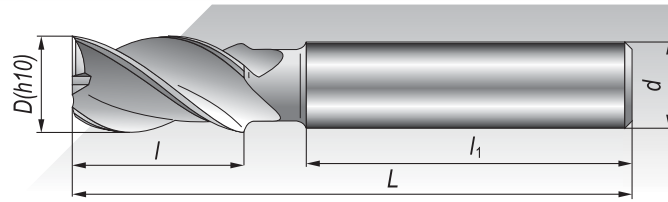
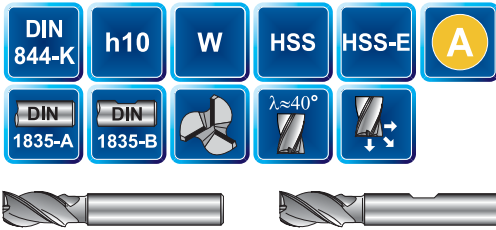

DIN 844-A K-M-W

DIN 844-B K-M-W

DIN 844-A K-M-W

D _(h10)	d _(h8)	l	l ₁	L	Z	HSS	HSS Golden	HSS-E	HSS-E Golden
6	6	13	36	57	3	●	○	○	○
8	10	19	40	69	3	●	○	○	○
10	10	22	40	72	3	●	○	○	○
12	12	26	45	83	3	●	○	○	○
14	12	26	45	83	3	●	○	○	○
16	16	32	48	92	3	●	○	○	○
20	20	38	50	104	4	●	○	○	○
22	20	38	50	104	4	○	○	○	○
25	25	45	56	121	4	○	○	○	○
28	25	45	56	121	4	○	○	○	○
30	25	45	56	121	4	○	○	○	○
32	32	53	60	133	4	○	○	○	○

Przykład zamówienia; Example of order: Frez; End mill DIN 844-A 10 K-M-W HSS

- Frezy; End mills DIN 844-B K-M-W
- Frezy; End mills DIN 844-B K-M-W Golden

**Frezy trzpieniowe walcowo-czołowe, krótkie do metali lekkich z chwytem walcowym;
End mills for light metals, short with straight shank**

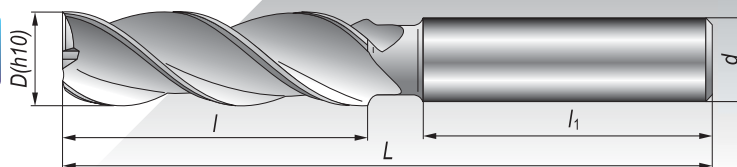

DIN 844-A L-M-W

DIN 844-B L-M-W

DIN 844-A L-M-W

D _(h10)	d _(h8)	l	l ₁	L	Z	HSS	HSS Golden	HSS-E	HSS-E Golden
6	6	24	36	68	3	●	○	○	○
8	10	38	40	88	3	●	○	○	○
10	10	45	40	95	3	●	○	○	○
12	12	53	45	110	3	●	○	○	○
14	12	53	45	110	3	●	○	○	○
16	16	63	48	123	3	●	○	○	○
20	20	75	50	141	4	○	○	○	○
22	20	75	50	141	4	○	○	○	○
25	25	90	56	166	4	○	○	○	○
28	25	90	56	166	4	○	○	○	○
30	25	90	56	166	4	○	○	○	○
32	32	106	60	186	4	○	○	○	○

Przykład zamówienia; Example of order: Frez; End mill DIN 844-A 10 L-M-W HSS

- Frezy; End mills DIN 844-B L-M-W
- Frezy; End mills DIN 844-B L-M-W Golden

Na specjalne zamówienie wykonujemy narzędzia o wymiarach innych niż zawarte w tabeli;
For the special order we make tools of other dimensions than contained in table.

**Frezy trzpieniowe walcowo-czołowe, długie do metali lekkich z chwytem walcowym;
End mills for light metals, long with straight shank**

DIN 845-B K-M-W

www.fenes.com.pl

FREZY; END MILLS

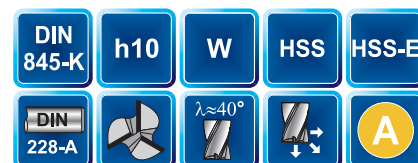
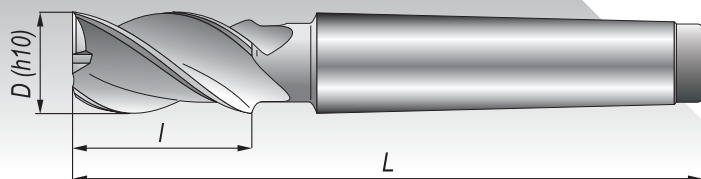

D _(h10)	l	L	Nr stoż.; MT	Z	HSS	HSS Golden	HSS-E	HSS-E Golden
10	22	92	1	3	○	○	○	○
11	22	92	1	3	○	○	○	○
12	26	96	1	3	○	○	○	○
13	26	96	1	3	○	○	○	○
14	26	111	2	3	○	○	○	○
15	26	111	2	3	○	○	○	○
16	32	117	2	3	○	○	○	○
17	32	117	2	3	○	○	○	○
18	32	117	2	3	○	○	○	○
19	32	117	2	3	○	○	○	○
20	38	123	2	4	○	○	○	○
21	38	123	2	4	○	○	○	○
22	38	123	2	4	○	○	○	○
23	38	123	2	4	○	○	○	○
24	45	147	3	4	○	○	○	○
25	45	147	3	4	○	○	○	○
26	45	147	3	4	○	○	○	○
27	45	147	3	4	○	○	○	○
28	45	147	3	4	○	○	○	○
29	45	147	3	4	○	○	○	○
30	45	147	3	4	○	○	○	○
32	53	178	4	4	○	○	○	○

Przykład zamówienia; Example of order: Frez; End mill DIN 845-B 10 K-M-W HSS

Na specjalne zamówienie wykonujemy narzędzia o wymiarach innych niż zawarte w tabeli;
For the special order we make tools of other dimensions than contained in table.

DIN 845-B L-M-W

FREZY; END MILLS

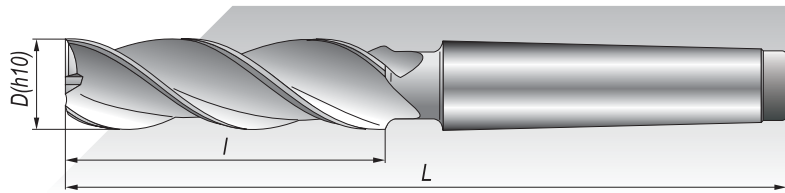

$D_{(h10)}$	l	L	Nr stoż.; MT	Z	HSS	HSS Golden	HSS-E	HSS-E Golden
10	45	115	1	3	○	○	○	○
11	45	115	1	3	○	○	○	○
12	53	123	1	3	○	○	○	○
13	53	123	1	3	○	○	○	○
14	53	138	2	3	○	○	○	○
15	53	138	2	3	○	○	○	○
16	63	148	2	3	○	○	○	○
18	63	148	2	3	○	○	○	○
20	75	160	2	4	○	○	○	○
22	75	160	2	4	○	○	○	○
24	90	192	3	4	○	○	○	○
25	90	192	3	4	○	○	○	○
26	90	192	3	4	○	○	○	○
28	90	192	3	4	○	○	○	○
30	90	192	3	4	○	○	○	○
32	106	231	4	4	○	○	○	○

Przykład zamówienia; Example of order: Frez; End mill DIN 845-B 10 L-M-W HSS

Na specjalne zamówienie wykonujemy narzędzia o wymiarach innych niż zawarte w tabeli;
For the special order we make tools of other dimensions than contained in table.

Frezy trzpieniowe walcowo-czołowe, długie do metali lekkich z chwytem stożkowym Morse'a;
End mills for light metals, long with Morse taper shank

FREZY; END MILLS

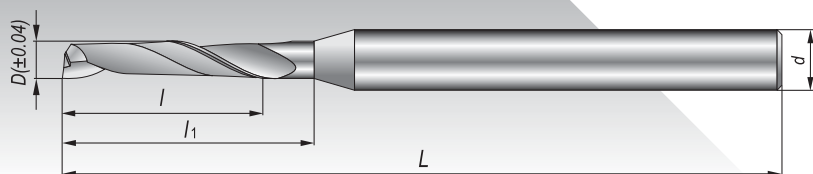

$D_{[\pm 0.04]}$	d	l	l_1	L	HSS	HSS Golden	HSS-E	HSS-E Golden
4	8	12	17	80	○	○	○	○
5	8	14	19	80	○	○	○	○
5	8	16	21	100	○	○	○	○
5	8	16	21	120	○	○	○	○
5	8	30	35	100	●	○	●	○
5	8	35	40	100	●	○	●	○
8	8	25	-	100	○	○	○	○
8	8	25	-	120	○	○	○	○
10	10	14	-	100	○	○	○	○
10	10	14	-	120	○	○	○	○
10	10	45	-	100	○	○	○	○
10	10	45	-	120	○	○	○	○

Przykład zamówienia; Example of order: Frez; Fly cutter NFPo 5x30 HSS-E

Na specjalne zamówienie wykonujemy narzędzia o wymiarach innych niż zawarte w tabeli;
For the special order we make tools of other dimensions than contained in table.

NFPj, NFPz

FREZY; END MILLS

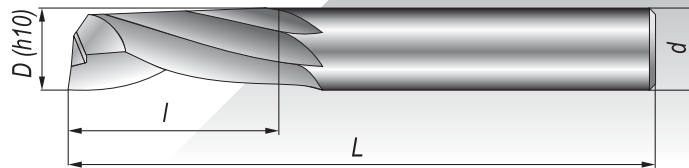

NFPj					
$D_{[h10]}$	$d_{[h6]}$	l	L	HSS-E	HSS-E Golden
6	6	20	57	●	○
8	8	22	63	●	○
10	10	25	72	●	○
12	12	30	83	○	○

Przykład zamówienia; Example of order: Frez; Fly cutter NFPj 10 HSS-E

Frezy trzpieniowe 1-ostrowe do metali lekkich i tworzyw sztucznych, uniwersalne;
Fly cutters for light metals and plastics, universal

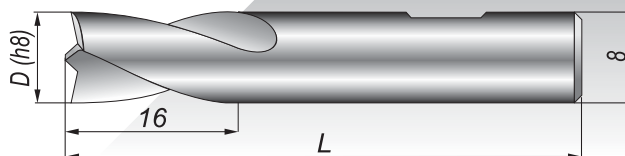
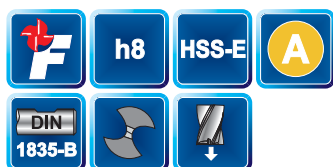

NFPz			
$D_{[h8]}$	L	HSS-E	HSS-E Golden
8	36	●	○
8	45	●	○

Przykład zamówienia; Example of order: Frez; End mill NFPz 8x36 HSS-E

Na specjalne zamówienie wykonujemy narzędzia o wymiarach innych niż zawarte w tabeli;
For the special order we make tools of other dimensions than contained in table.

Frezy trzpieniowe z chwytem walcowym do usuwania zgrzewów punktowych;
End mills with straight shank for spot welds removing

DIN 1889-BA, BB

www.fenes.com.pl

FREZY; END MILLS

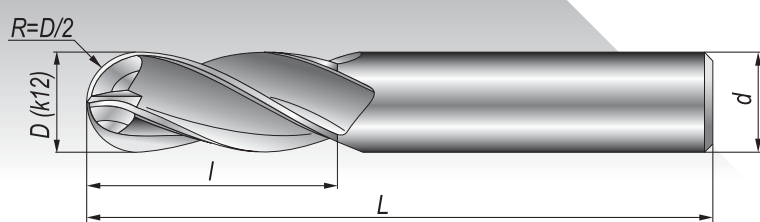

DIN 1889-BA K-H

DIN 1889-BB K-H

K - odmiana krótka;
K - short type

					DIN 1889-BA K-H			
D _[k12]	d _[h8]	l	L	Z	HSS	HSS Golden	HSS-E	HSS-E Golden
6	6	13	57	4	●	○	○	○
8	10	19	69	4	●	○	○	○
10	10	22	72	4	●	○	○	○
12	12	26	83	4	●	○	○	○
16	16	32	92	4	●	○	○	○
20	20	38	104	4	●	○	○	○
25	25	45	121	6	○	○	○	○
32	32	53	133	6	○	○	○	○

Przykład zamówienia; Example of order: Frez; End mill DIN 1889-BA 8 K-H HSS

- Frezy; End mills DIN 1889-BB K-H
- Frezy; End mills DIN 1889-BB K-H Golden



DIN 1889-BA L-H

DIN 1889-BB L-H

L - odmiana długa;
L - long type

					DIN 1889-BA L-H			
D _[k12]	d _[h8]	l	L	Z	HSS	HSS Golden	HSS-E	HSS-E Golden
6	6	24	68	4	○	○	○	○
8	10	38	88	4	○	○	○	○
10	10	45	95	4	○	○	○	○
12	12	53	110	4	○	○	○	○
16	16	63	123	4	○	○	○	○
20	20	75	141	4	○	○	○	○
25	25	90	166	6	○	○	○	○
32	32	106	186	6	○	○	○	○

Przykład zamówienia; Example of order: Frez; End mill DIN 1889-BA 8 L-H HSS

- Frezy; End mills DIN 1889-BB L-H
- Frezy; End mills DIN 1889-BB L-H Golden

Na specjalne zamówienie wykonujemy narzędzia o wymiarach innych niż zawarte w tabeli;
For the special order we make tools of other dimensions than contained in table.

DIN 1889-EA, EB

FREZY; END MILLS

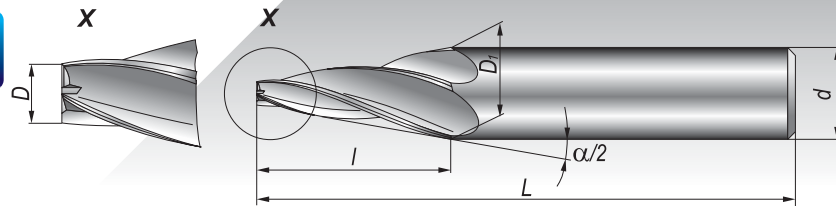

DIN 1889-EA K-H



DIN 1889-EB K-H

K - odmiana krótka;
K - short type

DIN 1889-EA K-H											
Pochylenie; Inclination	D	D ₁	d _(H8)	l	L	α/2	Z	HSS	HSS Golden	HSS-E	HSS-E Golden
1:6	4	16	16	36	93	9°28'	4	o	o	o	o
1:6	6	20	20	42	106	9°28'	4	o	o	o	o
1:6	8	25	25	50	120	9°28'	4	o	o	o	o
1:6	12	33	32	63	135	9°28'	4	o	o	o	o
1:10	4	12	10	40	90	5°43'	4	o	o	o	o
1:10	6	14	12	40	95	5°43'	4	o	o	o	o
1:10	8	17	16	45	103	5°43'	4	o	o	o	o
1:10	12	21	20	45	106	5°43'	4	o	o	o	o
1:10	16	26	25	50	120	5°43'	4	o	o	o	o
1:20	4	8	8	40	90	2°52'	4	o	o	o	o
1:20	6	10	10	40	95	2°52'	4	o	o	o	o
1:20	8	12.5	12	45	105	2°52'	4	o	o	o	o
1:20	12	17	16	50	109	2°52'	4	o	o	o	o
1:20	16	21.6	20	56	120	2°52'	4	o	o	o	o
1:20	20	26.3	25	63	135	2°52'	4	o	o	o	o

Przykład zamówienia; Example of order: Frez; End mill DIN 1889-EA 1:20 8 K-H HSS

- o Frezy; End mills DIN 1889-EB K-H
- o Frezy; End mills DIN 1889-EB K-H Golden



DIN 1889-EA M-H

DIN 1889-EB M-H

M - odmiana średnio-długa;
M - medium long

DIN 1889-EA M-H											
Pochylenie; Inclination	D	D ₁	d _(H8)	l	L	α/2	Z	HSS	HSS Golden	HSS-E	HSS-E Golden
1:6	4	22.7	20	56	120	9°28'	4	o	o	o	o
1:6	6	27	25	63	135	9°28'	4	o	o	o	o
1:6	8	31.7	32	71	145	9°28'	4	o	o	o	o
1:10	4	16.6	16	63	125	5°43'	4	o	o	o	o
1:10	6	18.6	16	63	125	5°43'	4	o	o	o	o
1:10	8	22.2	20	71	135	5°43'	4	o	o	o	o
1:10	12	26.2	25	71	140	5°43'	4	o	o	o	o
1:20	4	10.3	10	63	115	2°52'	4	o	o	o	o
1:20	6	12.3	10	63	115	2°52'	4	o	o	o	o
1:20	8	16	16	80	138	2°52'	4	o	o	o	o
1:20	12	20	20	80	140	2°52'	4	o	o	o	o
1:20	16	25	25	90	160	2°52'	4	o	o	o	o
1:20	20	30	25	100	170	2°52'	4	o	o	o	o

Przykład zamówienia; Example of order: Frez; End mill DIN 1889-EA 1:20 8 M-H HSS

- o Frezy; End mills DIN 1889-EB M-H
- o Frezy; End mills DIN 1889-EB M-H Golden

Na specjalne zamówienie wykonujemy narzędzia o wymiarach innych niż zawarte w tabeli;
For the special order we make tools of other dimensions than contained in table.



Frezy stożkowe do matryc z czolem płaskim z chwytem walcowym;
Flat nosed tapered end mills for die-sinking with straight shank

FREZY; END MILLS

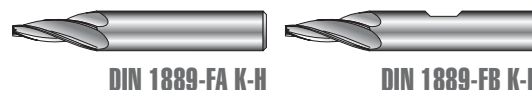
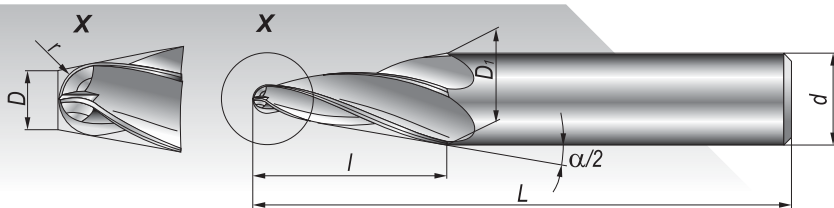

K - odmiana krótka;
K - short type

Pochylenie; Inclination	D	D ₁	d _(hsk)	l	L	r	α/2	Z	HSS	DIN 1889-FA K-H			
										HSS Golden	HSS-E	HSS-E Golden	
1:6	4	16	16	36	93	2.36	9°28'	4	○	○	○	○	
1:6	6	20	20	42	106	3.54	9°28'	4	○	○	○	○	
1:6	8	25	25	50	120	4.72	9°28'	4	○	○	○	○	
1:6	12	33	32	63	135	7.08	9°28'	4	○	○	○	○	
1:10	4	12	10	40	90	2.21	5°43'	4	○	○	○	○	
1:10	6	14	12	40	95	3.31	5°43'	4	○	○	○	○	
1:10	8	17	16	45	103	4.42	5°43'	4	○	○	○	○	
1:10	12	21	20	45	106	6.63	5°43'	4	○	○	○	○	
1:10	16	26	25	50	120	8.84	5°43'	4	○	○	○	○	
1:20	4	8	8	40	90	2.10	2°52'	4	○	○	○	○	
1:20	6	10	10	40	95	3.15	2°52'	4	○	○	○	○	
1:20	8	12.5	12	45	105	4.20	2°52'	4	○	○	○	○	
1:20	12	17	16	50	109	6.31	2°52'	4	○	○	○	○	
1:20	16	21.6	20	56	120	8.41	2°52'	4	○	○	○	○	
1:20	20	26.3	25	63	135	10.51	2°52'	4	○	○	○	○	

Przykład zamówienia; Example of order: Frez; End mill DIN 1889-FA 1:6 8 K-H HSS-E

- Frezy; End mills DIN 1889-FB K-H
- Frezy; End mills DIN 1889-FB K-H Golden



M - odmiana średnio-długa;
M - medium long

DIN 1889-FA M-H

DIN 1889-FB M-H

Pochylenie; Inclination	D	D ₁	d _(hsk)	l	L	r	α/2	Z	HSS	DIN 1889-FA M-H			
										HSS Golden	HSS-E	HSS-E Golden	
1:6	4	22.7	20	56	120	2.36	9°28'	4	○	○	○	○	
1:6	6	27	25	63	135	3.54	9°28'	4	○	○	○	○	
1:6	8	31.7	32	71	145	4.72	9°28'	4	○	○	○	○	
1:10	4	16.6	16	63	125	2.21	5°43'	4	○	○	○	○	
1:10	6	18.6	16	63	125	3.31	5°43'	4	○	○	○	○	
1:10	8	22.2	20	71	135	4.42	5°43'	4	○	○	○	○	
1:10	12	26.2	25	71	140	6.63	5°43'	4	○	○	○	○	
1:20	4	10.3	10	63	115	2.10	2°52'	4	○	○	○	○	
1:20	6	12.3	10	63	115	3.15	2°52'	4	○	○	○	○	
1:20	8	16	16	80	138	4.20	2°52'	4	○	○	○	○	
1:20	12	20	20	80	140	6.31	2°52'	4	○	○	○	○	
1:20	16	25	25	90	160	8.41	2°52'	4	○	○	○	○	
1:20	20	30	25	100	170	10.51	2°52'	4	○	○	○	○	

Przykład zamówienia; Example of order: Frez; End mill DIN 1889-FA 1:6 8 M-H HSS-E

- Frezy; End mills DIN 1889-FB M-H
- Frezy; End mills DIN 1889-FB M-H Golden

Na specjalne zamówienie wykonujemy narzędzia o wymiarach innych niż zawarte w tabeli;
For the special order we make tools of other dimensions than contained in table.