

FREZY; END MILLS

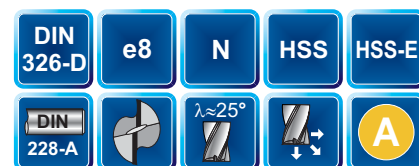

FREZY; END MILLS

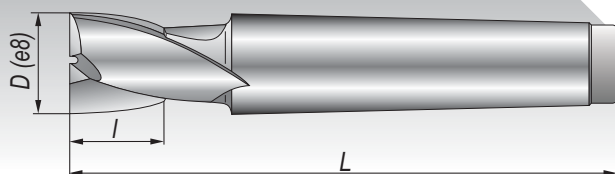

$D_{[e8]}$	l	L	Nr stoż; MT	HSS	HSS Golden	HSS-E	HSS-E Golden
10	13	83	1	●	○	○	○
12	16	86	1	●	○	○	○
14	16	101	2	●	○	○	○
16	19	104	2	●	○	○	○
18	19	104	2	●	○	○	○
20	22	107	2	●	○	○	○
22	22	107	2	●	○	○	○
24	26	128	3	●	○	○	○
25	26	128	3	●	○	○	○
28	26	128	3	●	○	○	○
30	26	128	3	●	○	○	○
32	32	157	4	●	○	○	○
36	32	157	4	●	○	○	○
38	38	163	4	●	○	○	○
40	38	163	4	●	○	○	○
45	38	163	4	●	○	○	○
50	45	203	5	●	○	○	○
56	45	203	5	○	○	○	○
63	53	211	5	○	○	○	○

Przykład zamówienia; Example of order: Frez; Slot drill DIN 326-D 20 HSS

Na specjalne zamówienie wykonujemy narzędzia o wymiarach innych niż zawarte w tabeli;
For the special order we make tools of other dimensions than contained in table.

DIN 327-(B, D) K

FREZY; END MILLS

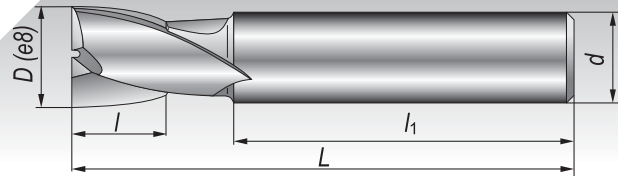

DIN 327-B K



DIN 327-D K

DIN 327-B K

$D_{[e8]}$	$d_{[H8]}$	l	l_1	L	HSS	HSS Golden	HSS-E	HSS-E Golden
3	6	5	36	49	●	●	●	○
3.5	6	6	36	50	●	○	○	○
4	6	7	36	51	●	●	●	○
4.5	6	7	36	51	●	○	○	○
5	6	8	36	52	●	●	●	○
6	6	8	36	52	●	●	●	○
6.5	10	10	40	60	●	○	○	○
7	10	10	40	60	●	●	●	○
8	10	11	40	61	●	●	●	○
8.5	10	11	40	61	●	○	○	○
9	10	11	40	61	●	●	●	○
10	10	13	40	63	●	●	●	○
11	12	13	45	70	●	●	●	○
12	12	16	45	73	●	●	●	○
13	12	16	45	73	●	●	●	○
14	12	16	45	73	●	●	●	○
15	12	16	45	73	●	●	●	○
16	16	19	48	79	●	●	●	○
17	16	19	48	79	●	○	○	○
18	16	19	48	79	●	●	●	○
19	16	19	48	79	●	○	○	○
20	20	22	50	88	●	●	●	○
21	20	22	50	88	●	○	○	○
22	20	22	50	88	●	●	●	○
23	20	22	50	88	●	○	○	○
24	25	26	56	102	●	○	○	○
25	25	26	56	102	●	○	○	○
26	25	26	56	102	●	○	○	○
28	25	26	56	102	●	○	○	○
30	25	26	56	102	●	○	○	○
32	32	32	60	112	●	○	○	○
35	32	32	60	112	○	○	○	○
36	32	32	60	112	○	○	○	○

Przykład zamówienia; Example of order: Frez; Slot drill DIN 327-B 10 K HSS

- Frezy; Slot drills DIN 327-D K
- Frezy; Slot drills DIN 327-D K Golden

Na specjalne zamówienie wykonujemy narzędzia o wymiarach innych niż zawarte w tabeli;
For the special order we make tools of other dimensions than contained in table.



DIN 327-(B, D) K-R

www.fenes.com.pl

FREZY; END MILLS

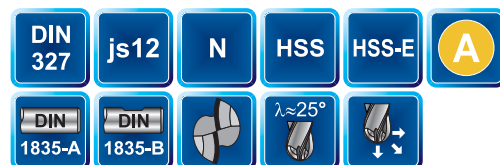
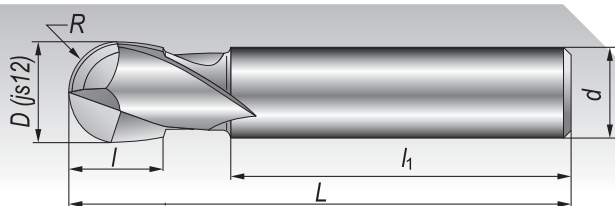

DIN 327-B K-R



DIN 327-D K-R



						DIN 327-B K-R			
D _[js12]	R	d _[h8]	l	l ₁	L	HSS	HSS Golden	HSS-E	HSS-E Golden
4	2	6	7	36	51	●	○	○	○
5	2.5	6	8	36	52	●	○	○	○
6	3	6	8	36	52	●	○	○	○
7	3.5	10	10	40	60	●	○	○	○
8	4	10	11	40	61	●	○	○	○
9	4.5	10	11	40	61	●	○	○	○
10	5	10	13	40	63	●	○	○	○
11	5.5	12	13	45	70	○	○	○	○
12	6	12	16	45	73	●	○	○	○
13	6.5	12	16	45	73	○	○	○	○
14	7	12	16	45	73	●	○	○	○
15	7.5	12	16	45	73	○	○	○	○
16	8	16	19	48	79	●	○	○	○
17	8.5	16	19	48	79	○	○	○	○
18	9	16	19	48	79	●	○	○	○
19	9.5	16	19	48	79	○	○	○	○
20	10	20	22	50	88	●	○	○	○
22	11	20	22	50	88	○	○	○	○
23	11.5	20	22	50	88	○	○	○	○
24	12	25	26	56	102	●	○	○	○
25	12.5	25	26	56	102	●	○	○	○
26	13	25	26	56	102	○	○	○	○
28	14	25	26	56	102	○	○	○	○
30	15	25	26	56	102	○	○	○	○
32	16	32	32	60	112	○	○	○	○

Przykład zamówienia; Example of order: Frez; Slot drill DIN 327-B 10 K-R5 HSS

- Frezy; Slot drills DIN 327-D K-R
- Frezy; Slot drills DIN 327-D K-R Golden

Na specjalne zamówienie wykonujemy narzędzia o wymiarach innych niż zawarte w tabeli;
For the special order we make tools of other dimensions than contained in table.

DIN 844-(A, B) K-N

FREZY; END MILLS

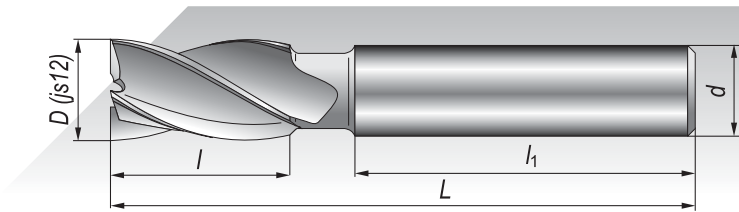

DIN 844-A K-N



DIN 844-B K-N

DIN 844-A K-N										
$D_{[js12]}$	$d_{[h8]}$	l	l_1	L	Z	HSS	HSS Golden	HSS-E	HSS-E Golden	
3	6	8	36	52	4	●	●	●	○	
3.5	6	10	36	54	4	●	○	○	○	
4	6	11	36	55	4	●	●	●	○	
4.5	6	11	36	55	4	●	○	○	○	
5	6	13	36	57	4	●	●	●	○	
5.5	6	13	36	57	4	●	○	○	○	
6	6	13	36	57	4	●	●	●	○	
6.5	10	16	40	66	4	●	○	●	○	
7	10	16	40	66	4	●	●	●	○	
7.5	10	16	40	66	4	●	○	○	○	
8	10	19	40	69	4	●	●	●	○	
8.5	10	19	40	69	4	●	○	○	○	
9	10	19	40	69	4	●	●	●	○	
9.5	10	19	40	69	4	●	○	○	○	
10	10	22	40	72	4	●	●	●	○	
10.5	12	22	45	79	4	●	○	○	○	
11	12	22	45	79	4	●	●	●	○	
11.5	12	22	45	79	4	●	○	○	○	
12	12	26	45	83	4	●	●	●	○	
12.5	12	26	45	83	4	●	○	○	○	
13	12	26	45	83	4	●	●	○	○	
14	12	26	45	83	4	●	●	●	○	
15	12	26	45	83	4	●	○	○	○	
16	16	32	48	92	4	●	●	●	○	
17	16	32	48	92	4	●	○	○	○	
18	16	32	48	92	4	●	●	●	○	
19	16	32	48	92	4	●	○	○	○	
20	20	38	50	104	4	●	●	●	○	
21	20	38	50	104	6	●	○	○	○	
22	20	38	50	104	6	●	●	○	○	
23	20	38	50	104	6	●	○	○	○	
24	25	45	56	121	6	●	○	○	○	
25	25	45	56	121	6	●	●	○	○	
26	25	45	56	121	6	●	○	○	○	
28	25	45	56	121	6	●	○	○	○	
30	25	45	56	121	6	●	○	○	○	
32	32	53	60	133	6	●	○	○	○	
34	32	53	60	133	6	○	○	○	○	
35	32	53	60	133	6	○	○	○	○	
36	32	53	60	133	6	○	○	○	○	

Przykład zamówienia; Example of order: Frez; End mill DIN 844-A 10 K-N HSS

- Frezy; End mills DIN 844-B K-N
- Frezy; End mills DIN 844-B K-N Golden

Na specjalne zamówienie wykonujemy narzędzia o wymiarach innych niż zawarte w tabeli;
For the special order we make tools of other dimensions than contained in table.



DIN 844-(A, B) K-M-N

www.fenes.com.pl

FREZY; END MILLS

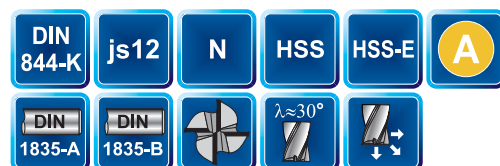
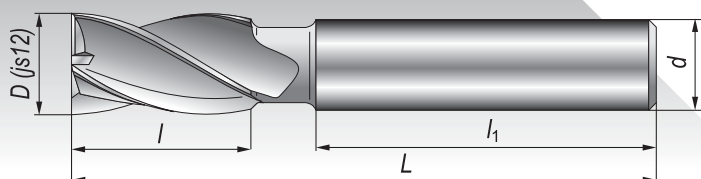

DIN 844-A K-M-N



DIN 844-B K-M-N



DIN 844-A K-M-N									
D _[js12]	d _[h8]	l	l ₁	L	Z	HSS	HSS Golden	HSS-E	HSS-E Golden
4	6	11	36	55	4	●	○	○	○
5	6	13	36	57	4	●	○	○	○
6	6	13	36	57	4	●	○	○	○
7	10	16	40	66	4	●	○	○	○
8	10	19	40	69	4	●	○	○	○
9	10	19	40	69	4	●	○	○	○
10	10	22	40	72	4	●	○	○	○
11	12	22	45	79	4	●	○	○	○
12	12	26	45	83	4	●	○	○	○
13	12	26	45	83	4	●	○	○	○
14	12	26	45	83	4	●	○	○	○
15	12	26	45	83	4	●	○	○	○
16	16	32	48	92	4	●	○	○	○
17	16	32	48	92	4	●	○	○	○
18	16	32	48	92	4	●	○	○	○
19	16	32	48	92	4	○	○	○	○
20	20	38	50	104	4	●	○	○	○
21	20	38	50	104	6	○	○	○	○
22	20	38	50	104	6	●	○	○	○
23	20	38	50	104	6	○	○	○	○
24	25	45	56	121	6	○	○	○	○
25	25	45	56	121	6	●	○	○	○
26	25	45	56	121	6	○	○	○	○
28	25	45	56	121	6	○	○	○	○
30	25	45	56	121	6	○	○	○	○
32	32	53	60	133	6	○	○	○	○

Przykład zamówienia; Example of order: Frez; End mill DIN 844-A 10 K-M-N HSS

- Frezy; End mills DIN 844-B K-M-N
- Frezy; End mills DIN 844-B K-M-N Golden

Na specjalne zamówienie wykonujemy narzędzia o wymiarach innych niż zawarte w tabeli;
For the special order we make tools of other dimensions than contained in table.

DIN 844-(A, B) L-N

FREZY; END MILLS

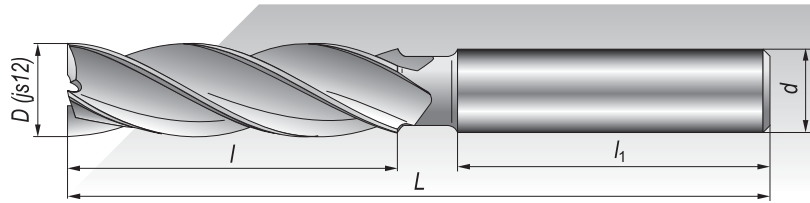

DIN 844-A L-N



DIN 844-B L-N

DIN 844-A L-N

D _[js12]	d _[h8]	l	l ₁	L	Z	HSS	HSS Golden	HSS-E	HSS-E Golden
3	6	12	36	56	4	●	○	●	○
3.5	6	15	36	59	4	●	○	○	○
4	6	19	36	63	4	●	●	●	○
4.5	6	19	36	63	4	●	○	○	○
5	6	24	36	68	4	●	●	●	○
5.5	6	24	36	68	4	○	○	○	○
6	6	24	36	68	4	●	●	●	○
6.5	10	30	40	80	4	●	○	●	○
7	10	30	40	80	4	●	●	●	○
7.5	10	30	40	80	4	●	○	○	○
8	10	38	40	88	4	●	●	●	○
8.5	10	38	40	88	4	●	○	○	○
9	10	38	40	88	4	●	○	●	○
9.5	10	38	40	88	4	●	○	○	○
10	10	45	40	95	4	●	●	●	○
11	12	45	45	102	4	●	○	○	○
12	12	53	45	110	4	●	●	●	○
13	12	53	45	110	4	●	○	○	○
14	12	53	45	110	4	●	●	●	○
15	12	53	45	110	4	●	○	○	○
16	16	63	48	123	4	●	●	○	○
17	16	63	48	123	4	●	○	●	○
18	16	63	48	123	4	●	●	●	○
19	16	63	48	123	4	○	○	●	○
20	20	75	50	141	4	●	●	○	○
21	20	75	50	141	6	○	○	●	○
22	20	75	50	141	6	●	○	○	○
23	20	75	50	141	6	○	○	●	○
24	25	90	56	166	6	●	○	○	○
25	25	90	56	166	6	●	○	○	○
26	25	90	56	166	6	○	○	○	○
28	25	90	56	166	6	●	○	○	○
30	25	90	56	166	6	○	○	○	○
32	32	106	60	186	6	○	○	○	○
34	32	106	60	186	6	○	○	○	○
35	32	106	60	186	6	○	○	○	○
36	32	106	60	186	6	○	○	○	○

Przykład zamówienia; Example of order: Frez; End mill DIN 844-A 10 L-N HSS

- Frezy; End mills DIN 844-B L-N
- Frezy; End mills DIN 844-B L-N Golden

Na specjalne zamówienie wykonujemy narzędzia o wymiarach innych niż zawarte w tabeli;
For the special order we make tools of other dimensions than contained in table.



DIN 844-(A, B) L-M-N

www.fenes.com.pl

FREZY; END MILLS

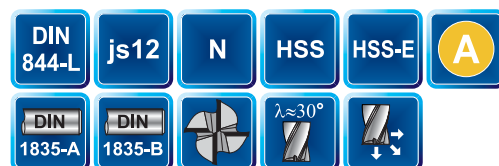
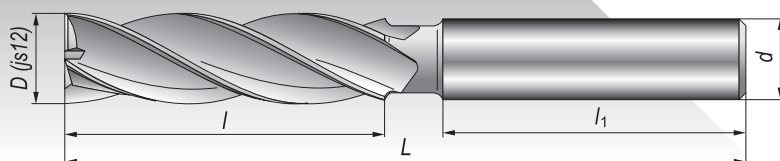

DIN 844-A L-M-N

DIN 844-B L-M-N



DIN 844-A L-M-N									
D _[js12]	d _[h8]	l	l ₁	L	Z	HSS	HSS Golden	HSS-E	HSS-E Golden
4	6	19	36	63	4	●	○	○	○
5	6	24	36	68	4	●	○	○	○
6	6	24	36	68	4	●	○	○	○
7	10	30	40	80	4	●	○	○	○
8	10	38	40	88	4	●	○	○	○
9	10	38	40	88	4	●	○	○	○
10	10	45	40	95	4	●	○	○	○
11	12	45	45	102	4	●	○	○	○
12	12	53	45	110	4	●	○	○	○
13	12	53	45	110	4	●	○	○	○
14	12	53	45	110	4	●	○	○	○
15	12	53	45	110	4	○	○	○	○
16	16	63	48	123	4	●	○	○	○
17	16	63	48	123	4	○	○	○	○
18	16	63	48	123	4	●	○	○	○
19	16	63	48	123	4	○	○	○	○
20	20	75	50	141	4	●	○	○	○
21	20	75	50	141	6	○	○	○	○
22	20	75	50	141	6	●	○	○	○
23	20	75	50	141	6	○	○	○	○
24	25	90	56	166	6	○	○	○	○
25	25	90	56	166	6	○	○	○	○
26	25	90	56	166	6	○	○	○	○
28	25	90	56	166	6	○	○	○	○
30	25	90	56	166	6	○	○	○	○
32	32	106	60	186	6	○	○	○	○

Przykład zamówienia; Example of order: Frez; End mill DIN 844-A 10 L-M-N HSS

- Frezy; End mills DIN 844-B L-M-N
- Frezy; End mills DIN 844-B L-M-N Golden

Na specjalne zamówienie wykonujemy narzędzia o wymiarach innych niż zawarte w tabeli;
For the special order we make tools of other dimensions than contained in table.

DIN 845-B K-N

FREZY; END MILLS

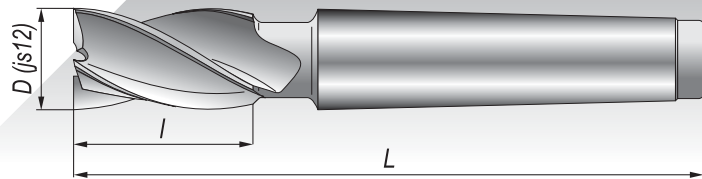

D _[js12]	l	L	Nrstoż; MT	Z	HSS	HSS Golden	HSS-E	HSS-E Golden
10	22	92	1	4	●	○	○	○
11	22	92	1	4	●	○	○	○
12	26	96	1	4	●	○	○	○
13	26	96	1	4	●	○	○	○
14	26	111	2	4	●	○	○	○
15	26	111	2	4	●	○	○	○
16	32	117	2	4	●	●	○	○
17	32	117	2	4	●	○	○	○
18	32	117	2	4	●	○	○	○
19	32	117	2	4	●	○	○	○
20	38	123	2	4	●	●	○	○
21	38	123	2	6	●	○	○	○
22	38	123	2	6	●	●	○	○
23	38	123	2	6	●	○	○	○
24	45	147	3	6	●	○	○	○
25	45	147	3	6	●	●	○	○
26	45	147	3	6	●	○	○	○
27	45	147	3	6	●	○	○	○
28	45	147	3	6	●	●	○	○
29	45	147	3	6	●	○	○	○
30	45	147	3	6	●	●	○	○
32	53	178	4	6	●	○	○	○
34	53	178	4	6	●	○	○	○
35	53	178	4	6	●	○	○	○
36	53	178	4	6	●	○	○	○
38	63	188	4	6	●	○	○	○
40	63	188	4	6	●	●	○	○
45	63	188	4	8	●	○	○	○
50	75	233	5	8	●	○	○	○
56	75	233	5	8	○	○	○	○
63	90	248	5	8	●	○	○	○

Przykład zamówienia; Example of order: Frez; End mill DIN 845-B 10 K-N HSS



Na specjalne zamówienie wykonujemy narzędzia o wymiarach innych niż zawarte w tabeli;
For the special order we make tools of other dimensions than contained in table.

Frezy trzpieniowe walcowo-czołowe, krótkie uniwersalne z chwytem stożkowym Morse'a;
End mills, short universal with Morse taper shank

DIN 845-B L-N

www.fenes.com.pl

FREZY; END MILLS

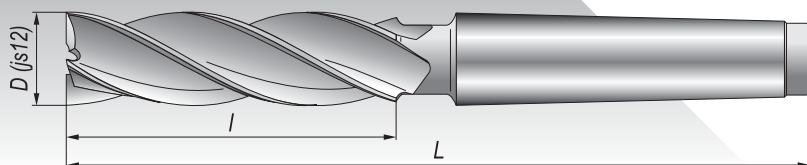

D _[js12]	l	L	Nr stoż; MT	Z	HSS	HSS Golden	HSS-E	HSS-E Golden
10	45	115	1	4	●	○	○	○
11	45	115	1	4	○	○	○	○
12	53	123	1	4	●	○	○	○
13	53	123	1	4	○	○	○	○
14	53	138	2	4	●	○	○	○
15	53	138	2	4	●	○	○	○
16	63	148	2	4	●	○	○	○
17	63	148	2	4	●	○	○	○
18	63	148	2	4	●	○	○	○
19	63	148	2	4	○	○	○	○
20	75	160	2	4	●	○	○	○
21	75	160	2	6	●	○	○	○
22	75	160	2	6	●	○	○	○
23	75	160	2	6	●	○	○	○
24	90	192	3	6	●	○	○	○
25	90	192	3	6	●	○	○	○
26	90	192	3	6	●	○	○	○
27	90	192	3	6	○	○	○	○
28	90	192	3	6	●	○	○	○
29	90	192	3	6	●	○	○	○
30	90	192	3	6	●	○	○	○
32	106	231	4	6	●	○	○	○
34	106	231	4	6	●	○	○	○
35	106	231	4	6	●	○	○	○
36	106	231	4	6	●	○	○	○
38	125	250	4	6	●	○	○	○
40	125	250	4	6	●	○	○	○
45	125	250	4	8	●	○	○	○
50	150	308	5	8	●	○	○	○
56	150	308	5	8	○	○	○	○
63	180	338	5	8	●	○	○	○

Przykład zamówienia; Example of order: Frez; End mill DIN 845-B 10 L-N HSS

Na specjalne zamówienie wykonujemy narzędzia o wymiarach innych niż zawarte w tabeli;
For the special order we make tools of other dimensions than contained in table.

DIN 1880-N, W

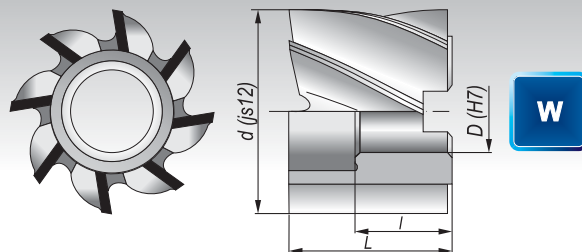
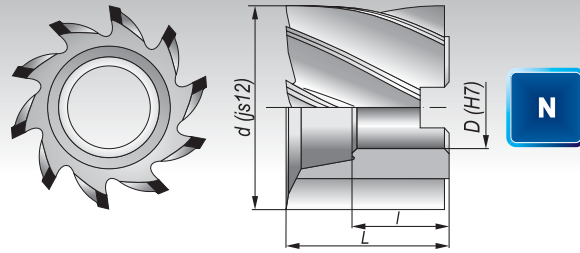

DIN 1880-NR

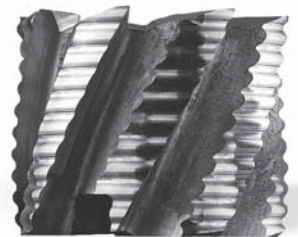
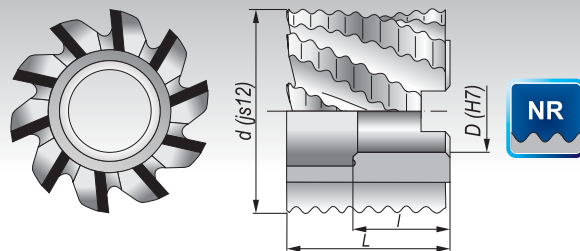

d _[js12]	D _[H7]	l	L	Z	DIN 1880-N		DIN 1880-W		
					HSS	HSS-E	Z	HSS	HSS-E
40	16	19	32	6	●	○	6	○	○
50	22	21	36	8	●	○	6	○	○
63	27	23	40	8	●	○	6	○	○
80	27	23	45	10	●	○	6	○	○
100	32	26	50	12	●	○	6	○	○
125	40	29	56	14	○	○	8	○	○

Przykład zamówienia; Example of order: Frez; Shell end mill DIN 1880-40 N HSS

○ Frezy; Shell end mills DIN 1880-NR

Na specjalne zamówienie wykonujemy narzędzia o wymiarach innych niż zawarte w tabeli;
For the special order we make tools of other dimensions than contained in table.

FREZY; END MILLS

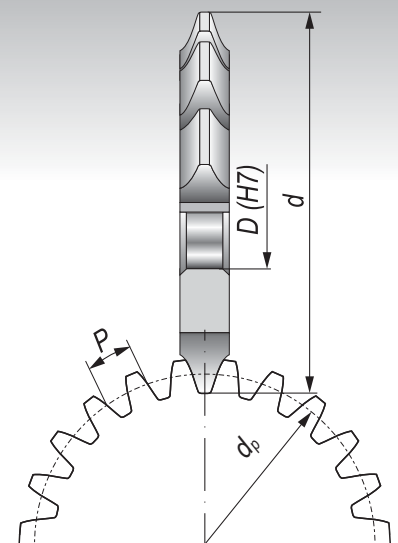

$$d_p = zm$$

$$m = P/\pi$$

gdzie; where

d_p - średnica podziałowa; pitch diameter

P - podziałka nominalna; nominal pitch (mierzona po łuku; measure along arc)

z - liczba zębów koła obrabianego; range of teeth cut

m - moduł nominalny; nominal module

P.A. - kąt przyporu 20°; pressure angle 20°

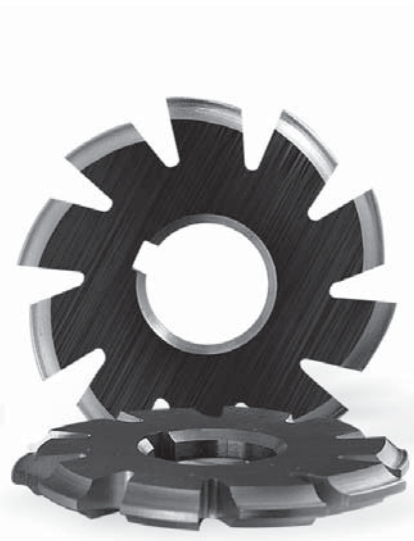

moduł; module	d	D _(H7)	Nr freza w kpl. / Liczba zębów koła obrabianego; Number of cutter in set / Range of teeth cut								kpl.; set
			#1 12÷13	#2 14÷16	#3 17÷20	#4 21÷25	#5 26÷34	#6 35÷54	#7 55÷134	#8 135÷∞	
0.5	40	16	○	○	○	○	○	○	○	○	○
0.7	40	16	●	●	●	●	●	●	●	●	●
0.75	40	16	●	●	●	●	●	●	●	●	●
0.8	40	16	○	○	○	○	○	○	○	○	○
1	50	16	●	●	●	●	●	●	●	●	●
1.25	50	16	●	●	●	●	●	●	●	●	●
1.5	56	22	●	●	●	●	●	●	●	●	●
1.75	56	22	●	●	●	●	●	●	●	●	●
2	63	22	●	●	●	●	●	●	●	●	●
2.25	63	22	●	●	●	●	●	●	●	●	●
2.5	63	22	●	●	●	●	●	●	●	●	●
2.75	71	27	●	●	●	●	●	●	●	●	●
3	71	27	●	●	●	●	●	●	●	●	●
3.25	71	27	○	○	○	○	○	○	○	○	○
3.5	80	27	●	●	●	●	●	●	●	●	●
3.75	80	27	○	○	○	○	○	○	○	○	○
4	80	27	●	●	●	●	●	●	●	●	●
4.5	90	32	●	●	●	●	●	●	●	●	●
5	90	32	●	●	●	●	●	●	●	●	●
6	100	32	○	○	○	○	○	○	○	○	○
7	100	32	○	○	○	○	○	○	○	○	○

Przykład zamówienia; Example of order: Frez; Involute gear cutter NFMa m=1.5#1

Na specjalne zamówienie wykonujemy narzędzia o wymiarach innych niż zawarte w tabeli;
For the special order we make tools of other dimensions than contained in table.